

OXFORD CAMBRIDGE AND RSA EXAMINATIONS

**Advanced Subsidiary General Certificate of Education
Advanced General Certificate of Education**

MATHEMATICS

4729

Mechanics 2

Monday

19 JUNE 2006

Morning

1 hour 30 minutes

Additional materials:

- 8 page answer booklet
- Graph paper
- List of Formulae (MF1)

TIME 1 hour 30 minutes

INSTRUCTIONS TO CANDIDATES

- Write your name, centre number and candidate number in the spaces provided on the answer booklet.
- Answer **all** the questions.
- Give non-exact numerical answers correct to 3 significant figures unless a different degree of accuracy is specified in the question or is clearly appropriate.
- The acceleration due to gravity is denoted by $g \text{ m s}^{-2}$. Unless otherwise instructed, when a numerical value is needed, use $g = 9.8$.
- You are permitted to use a graphical calculator in this paper.

INFORMATION FOR CANDIDATES

- The number of marks is given in brackets [] at the end of each question or part question.
- The total number of marks for this paper is 72.
- Questions carrying smaller numbers of marks are printed earlier in the paper, and questions carrying larger numbers of marks later in the paper.
- **You are reminded of the need for clear presentation in your answers.**

This question paper consists of 5 printed pages and 3 blank pages.

- 1 A child of mass 35 kg runs up a flight of stairs in 10 seconds. The vertical distance climbed is 4 m. Assuming that the child's speed is constant, calculate the power output. [4]
- 2 A small sphere of mass 0.3 kg is dropped from rest at a height of 2 m above horizontal ground. It falls vertically, hits the ground and rebounds vertically upwards, coming to instantaneous rest at a height of 1.4 m above the ground. Ignoring air resistance, calculate the magnitude of the impulse which the ground exerts on the sphere when it rebounds. [5]

3

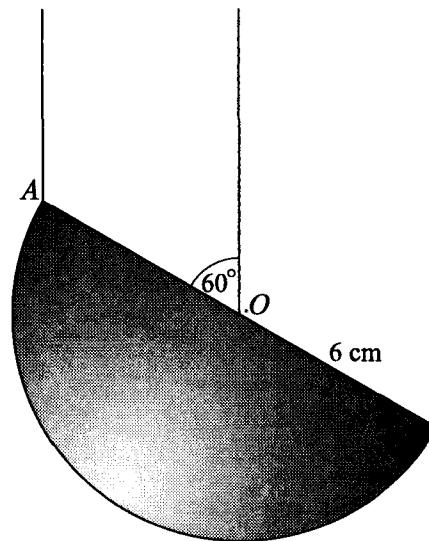

A uniform solid hemisphere of weight 12 N and radius 6 cm is suspended by two vertical strings. One string is attached to the point O , the centre of the plane face, and the other string is attached to the point A on the rim of the plane face. The hemisphere hangs in equilibrium and OA makes an angle of 60° with the vertical (see diagram).

- (i) Find the horizontal distance from the centre of mass of the hemisphere to the vertical through O . [2]
- (ii) Calculate the tensions in the strings. [5]

- 4 A car of mass 900 kg is travelling at a constant speed of 30 m s^{-1} on a level road. The total resistance to motion is 450 N.

(i) Calculate the power output of the car's engine. [1]

A roof box of mass 50 kg is mounted on the roof of the car. The total resistance to motion of the vehicle increases to 500 N.

(ii) The car's engine continues to work at the same rate. Calculate the maximum speed of the car on the level road. [2]

The power output of the car's engine increases to 15 000 W. The resistance to motion of the car, with roof box, remains 500 N.

(iii) Calculate the instantaneous acceleration of the car on the level road when its speed is 25 m s^{-1} . [3]

(iv) The car climbs a hill which is at an angle of 5° to the horizontal. Calculate the instantaneous retardation of the car when its speed is 26 m s^{-1} . [3]

5

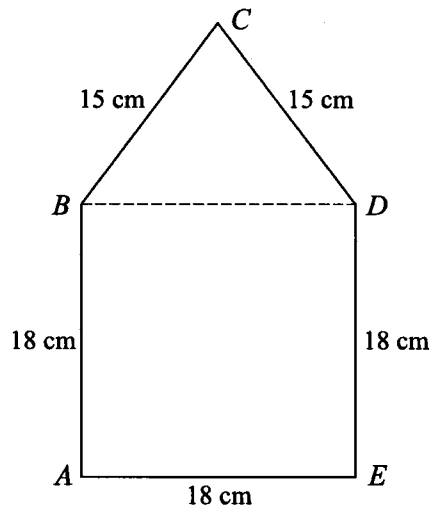

A uniform lamina $ABCDE$ consists of a square and an isosceles triangle. The square has sides of 18 cm and $BC = CD = 15 \text{ cm}$ (see diagram).

(i) Taking x - and y -axes along AE and AB respectively, find the coordinates of the centre of mass of the lamina. [7]

(ii) The lamina is freely suspended from B . Calculate the angle that BD makes with the vertical. [2]

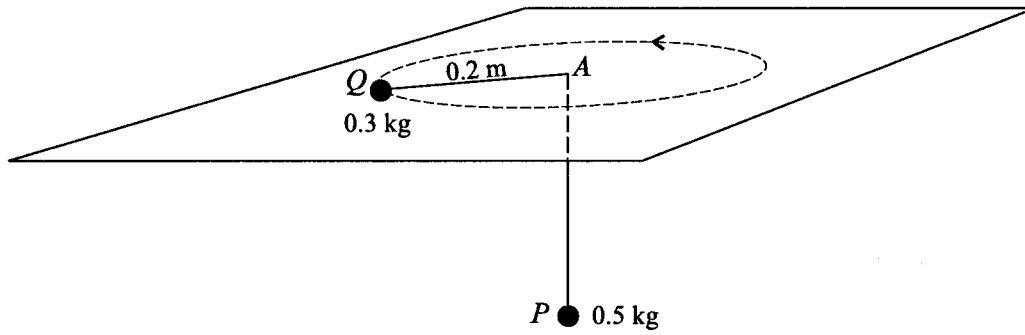

Fig. 1

A light inextensible string of length 1 m passes through a small smooth hole A in a fixed smooth horizontal plane. One end of the string is attached to a particle P , of mass 0.5 kg, which hangs in equilibrium below the plane. The other end of the string is attached to a particle Q , of mass 0.3 kg, which rotates with constant angular speed in a circle of radius 0.2 m on the surface of the plane (see Fig. 1).

- (i) Calculate the tension in the string and hence find the angular speed of Q . [4]

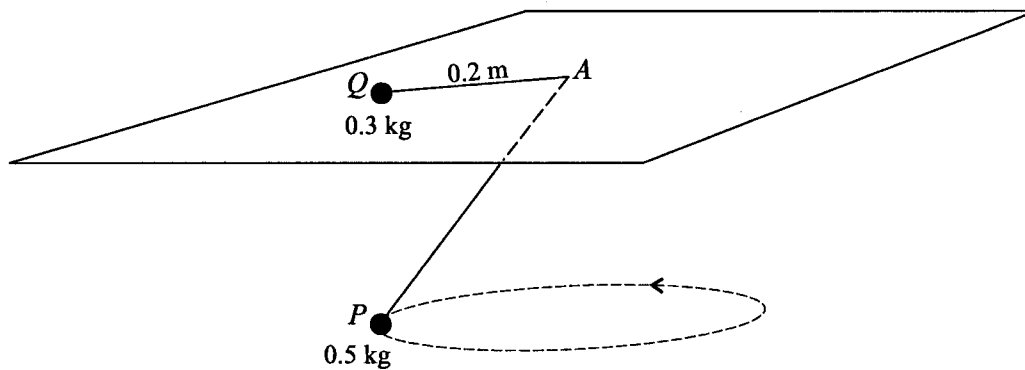

Fig. 2

The particle Q on the plane is now fixed to a point 0.2 m from the hole at A and the particle P rotates in a horizontal circle of radius 0.2 m (see Fig. 2).

- (ii) Calculate the tension in the string. [4]
 (iii) Calculate the speed of P . [3]

- 7 A small ball is projected at an angle of 50° above the horizontal, from a point A , which is 2 m above ground level. The highest point of the path of the ball is 15 m above the ground, which is horizontal. Air resistance may be ignored.

(i) Find the speed with which the ball is projected from A . [3]

The ball hits a net at a point B when it has travelled a horizontal distance of 45 m.

(ii) Find the height of B above the ground. [6]

(iii) Find the speed of the ball immediately before it hits the net. [4]

- 8 Two uniform smooth spheres, A and B , have the same radius. The mass of A is 2 kg and the mass of B is m kg. Sphere A is travelling in a straight line on a smooth horizontal surface, with speed 5 m s^{-1} , when it collides directly with sphere B , which is at rest. As a result of the collision, sphere A continues in the same direction with a speed of 2 m s^{-1} .

(i) Find the greatest possible value of m . [3]

It is given that $m = 1$.

(ii) Find the coefficient of restitution between A and B . [3]

On another occasion A and B are travelling towards each other, each with speed 5 m s^{-1} , when they collide directly.

(iii) Find the kinetic energy lost due to the collision. [8]

Mark scheme for M2 4729 (June 2006) – (final)

| | | | | | |
|----------|--|--------------------------------|----|---|----------------------|
| | | | | | |
| 1 | | $mgh = 35 \times 9.8 \times 4$ | M1 | | |
| | | | A1 | | |
| | | $mgh/t = 1372/10$ | M1 | | watch out for extras |
| | | 137 W | A1 | 4 | or 0.137 kW 4 |

| | | | | | | |
|----------|--|--|-----|---|-------------------------------|----------|
| 2 | | $v^2 = 2gh$ | M1 | | kinematics or energy | |
| | | $u = \sqrt{4g}$ or $\sqrt{39.2}$ or 6.26 | A1 | | speed of impact (\pm) | |
| | | $v = \sqrt{2.8g}$ or $\sqrt{27.44}$ (5.24) | A1 | | speed of rebound (\pm) | |
| | | $I = c \cdot 0.3(6.26 + 5.24)$ | M1 | | must be sum of mags. of vels. | |
| | | 3.45 Ns | A1✓ | 5 | ✓ must be positive | 5 |

| | | | | | | |
|----------|------|---|-----|---|---|----------|
| 3 | (i) | $d = 2.25$ | B1 | | $3/8 \times 6$ OG (be generous) | |
| | | $h = 1.125$ or 1.12 or 1.13 or 9/8 | B1 | 2 | horizontal distance | |
| | (ii) | $T_1 + T_2 = 12$ resolving vertically | M1 | | if not then next M1 ok | |
| | | $T_1 \times 6\cos 30^\circ = 12xh$ (their h) | M1 | | or $\text{mom}(A)T_2 \times 6\cos 30^\circ =$ | |
| | | $\text{mom}(O)$ (their h ok for A1) | A1 | | $12(6\cos 30^\circ - h)$ | |
| | | $T_1 = 2.60$ N or $3\sqrt{3}/2$ | A1 | | or $T_2 = 9.40$ | |
| | | $T_2 = 9.40$ N ✓ ($12 - T_1$) | A1✓ | 5 | or $T_1 = 2.60$ or ✓ ($12 - T_2$) | 7 |
| | | above ✓ depends on at least one of the M marks (T_s A 0) | | | | |

| | | | | | | |
|----------|-------|--------------------------------|----|---|------------------|----------|
| 4 | (i) | $P = 13500$ W | B1 | 1 | or 13.5 kW | |
| | (ii) | $500 = 13500/v$ | M1 | | | |
| | | $v = 27$ ms ⁻¹ | A1 | 2 | | |
| | (iii) | $15000/25 - 500 = 950a$ | M1 | | 2 parts to F | |
| | | | A1 | | A0 for 900a | |
| | | $a = 0.105$ or 2/19 | A1 | 3 | or 100/950 | |
| | (iv) | $15000/26 - 500 -$ | M1 | | 3 parts to F | |
| | | $950.9.8\sin 5^\circ = 950a$ | A1 | | A0 for 900a | |
| | | $a = (-).773$ ms ⁻² | A1 | 3 | s.c. accept 0.77 | 9 |

| | | | | | | |
|----------|------|--|-----|---|---|----------|
| 5 | (i) | $\bar{x} = 9$ | B1 | | ignore any working | |
| | | c of m of Δ 4 cm above BD | B1 | | 8 cm below C/see their diagram | |
| | | $(324 + 108)(m) \bar{y} =$ | M1 | | $432 \bar{y} = 108 \times 8 + 18^2 (12 + 9)$ | |
| | | $324(m) \times 9 + 108(m) \times (18 + 4)$ | | | from C | |
| | | $432 \bar{y}$ | A1 | | left hand side | |
| | | 324×9 ($18^2 \times 9$) | A1 | | 1 st term on right hand side 2916 | |
| | | $108 \times (18 + 4)$ | A1 | | 2 nd term on right hand side 2376 | |
| | | $\bar{y} = 12.25$ | A1 | 7 | $5292 \div 432$ or 49/4 | |
| | (ii) | $\tan \theta = 5.75/9$ | M1 | | must be .../9 | |
| | | $\theta = 32.6^\circ$ or 147.4° | A1✓ | 2 | ✓ $\tan^{-1} ((18 - \text{their } \bar{y})/9)$ or $180^\circ..$ | 9 |

| | | | | | | |
|---|-------|---------------------------------------|----|---|--|-----------|
| 6 | (i) | T = 4.9 N | B1 | | B0 for 0.5g | |
| | | T = 0.3 x 0.2 x ω^2 | M1 | | or $0.3v^2/0.2$ and $\omega = v/0.2$ | |
| | | | A1 | | | |
| | | $\omega = 9.04 \text{ rads}^{-1}$ | A1 | 4 | | |
| | (ii) | $\cos\theta = \sqrt{0.6/0.8}$ (0.968) | B1 | | ($\theta=14.5^\circ$) angle to vert. or equiv. | |
| | | Tcos $\theta = 0.5 \times 9.8$ | M1 | | angle consistent with diagram | |
| | | | A1 | | can be their angle | |
| | (iii) | T = 5.06 N | A1 | 4 | | |
| | | Tsin $\theta = 0.5 \times v^2/0.2$ | M1 | | must be a component of T | |
| | | | A1 | | (sin $\theta = 1/4$) can be their angle | |
| | | $v = 0.711 \text{ ms}^{-1}$ | A1 | 3 | | 11 |

| | | | | | | |
|---|-------|---|-----------------|---|--|-----------|
| 7 | (i) | $v\sin 50^\circ$ | B1 | | initial vertical component | |
| | | $0 = v^2\sin^2 50^\circ - 2 \times 9.8 \times 13$ (must be 13) | M1 | | or $m \times 9.8 \times 13 = \frac{1}{2}m(v\sin 50^\circ)^2$ | |
| | | $v = 20.8 \text{ ms}^{-1}$ | A1 | 3 | sin/cos mix ok for above M1 | |
| | (ii) | $45 = v\cos 50^\circ \cdot t$ | M1 | | see alternative below | |
| | | $t = 3.36 \checkmark$ their v (3.13 for $v=22.4$) | A1 \checkmark | | other methods include other t_s | |
| | | $s = v\sin 50^\circ \times t - \frac{1}{2} \times 9.8 \times t^2$ | M1 | | ignore ht adjustments | |
| | | | A1 | | can be their v and their t | |
| | | $s = -1.6$ to -2.0 inclusive (-1.68) | A1 | | can be implied from next A1 | |
| | | ht above ground = 0.320 m | A1 | 6 | | |
| | (iii) | $v_v = v\sin 50^\circ - 9.8xt$ | M1 | | or $v_v^2 = 2g(15 - \text{their ans to ii})$ | |
| | | $v_v = -17.0 \checkmark$ their v, t (-13.5 for 22.4) | A1 \checkmark | | \checkmark above for v_v | |
| | | speed = $\sqrt{(v_v^2 + (v\cos 50^\circ)^2)}$ | M1 | | or $\frac{1}{2}mv^2 - mg \times 1.68 = \frac{1}{2}m \times 20.8^2$ (4 marks) | |
| | | speed = $21.6 \text{ ms}^{-1} \checkmark$ their v and v_v (19.7 for $v = 22.4$) | A1 \checkmark | 4 | M1/A1 \checkmark s,v /M1 solve/ A1 \checkmark | 13 |
| | (ii) | $y = x\tan\theta - gx^2/2v^2\cos^2\theta$ | B1 | | Alternative 1st 5 marks | |
| | | $y = 45\tan 50^\circ - 9.8 \cdot 45^2 / 2 \cdot v^2 \cos^2 50^\circ$ | M1 | | substitute v and 50° and $x=45$ | |
| | | | A1 | | can be their v | |
| | | calculate y | M1 | | | |
| | | $y = -1.6$ to -2.0 inclusive | A1 | | should be -1.68 | |

| | | | | | | |
|---|-------|---|----|---|-------------------------------|-----------|
| 8 | (i) | $10 = 4 + m \cdot x$ | M1 | | conservation of momentum | |
| | | e = ... or rationale for $x = 2$ | M1 | | | |
| | | $m = 3$ | A1 | 3 | | |
| | (ii) | $v = 6$ | B1 | | | |
| | | $e = 4/5$ or 0.8 | M1 | | allow sign errors for M mark | |
| | | | A1 | 3 | watch out for lost minuses | |
| | (iii) | $10 - 5 = 2x + y$ ($5 = -2a + b$) | M1 | | | |
| | | $(-5 = 2c + d)$ | A1 | | | |
| | | $e = 0.8 = (y-x)/10$ | M1 | | look for consistency | |
| | | $y = x + 8$ ($a + b = 8$) ($c - d = 8$) | A1 | | | |
| | | $x = -1$ ($a=1$) ($c=1$) | A1 | | or 1 in opp. direction to 1st | |
| | | $y = 7$ ($b=7$) ($d=-7$) | A1 | | | |
| | | $\frac{1}{2} \cdot 2.5^2 + \frac{1}{2} \cdot 1.5^2 - \frac{1}{2} \cdot 2.1^2 - \frac{1}{2} \cdot 1.7^2$ | M1 | | K.E. lost. Must be 4 parts | |
| | | 12 J | A1 | 8 | (37.5 - 25.5) | 14 |

± 1 in 3rd sig. fig. except where stated